



# AMERICAN VISION CABINETS INC.

Made in the USA

**(805) 298-4411**

## CABINET COMPONENTS & PARTS

Our CNC capabilities allow us to precision machine a wide variety of cabinet components for the cabinet industry. Simply provide the dimensions, material specifications, and quantities. We'll handle the rest!



# 1 Series - Base/ Sink Cabinet

## A - Base

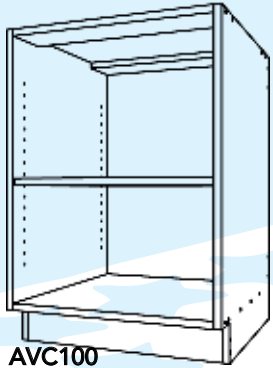

**AVC100**  
Open Base Cabinet

- Specify type and number of shelves on order form
- Interior surface shall be as listed on order form unless noted differently

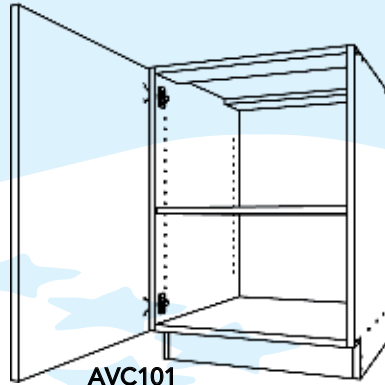

**AVC101**  
One-Door Base Cabinet

- Specify type and number of shelves on order form

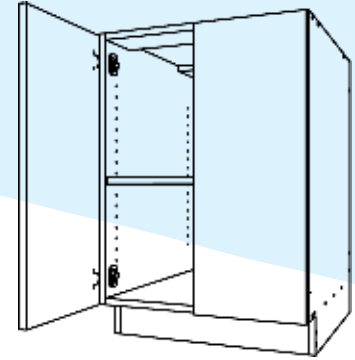

**AVC102**  
Two-Door Base Cabinet

- Specify type and number of shelves on order form

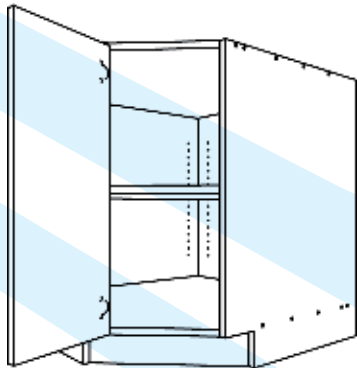

**AVC103**  
Two-Door at 45° Angle Corner Base Cabinet

- Specify type and number of shelves on order form
- \* Note: Constructed with 3/4" back

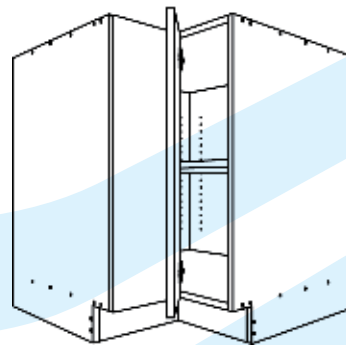

**AVC104**  
Two-Door Corner Base Cabinet

- Doors are hinged left or right and bi-fold in the center
- Lazy Susan - must specify diameter and material

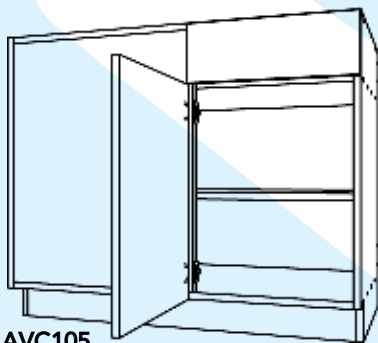

**AVC105**  
One-Door Corner Base Cabinet - One Drawer

- Specify type and number of shelves on order form
  - Specify width of false front panel
- Note: Hinged on false panel with face frame hinges.

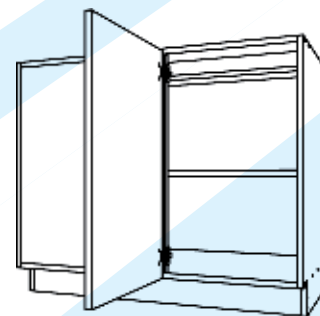

**AVC106**  
One-Door Corner Base Cabinet - False Panel

- Specify type and number of shelves on order form
  - Specify width of false front panel
  - Specify hinge right or left for false panel on opposite side
- Note: Hinged on false panel with face frame hinges.

# B - Sink Cabinet with false front

Sink cabinet with false drawer front. No top stretchers and a vertical false front backer is placed behind the false front.

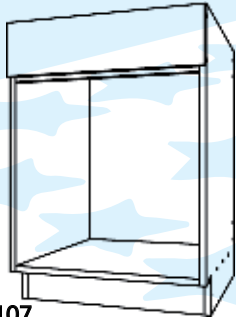

**AVC107**

Open Sink Cabinet - False Front

- Specify false front height
- Interior surface shall be as listed on order form unless noted differently
- Apron behind FF and hangs 1" lower

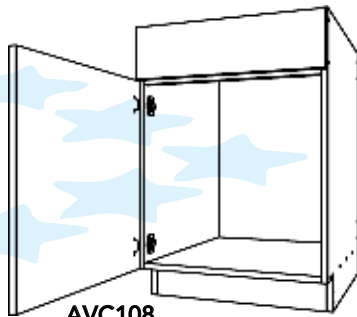

**AVC108**

One-Door Sink Cabinet - False Front

- Specify false front height
- Apron behind FF and hangs 1/2" lower

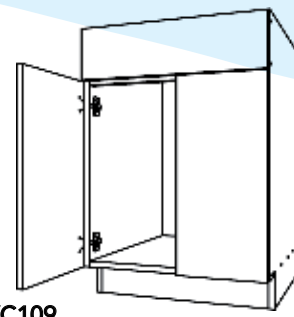

**AVC109**

Two-Door Sink Cabinet - False Front

- Specify false front height
- Apron behind FF and hangs 1/2" lower

# C - Sink Cabinet with full height doors

Cabinet with 7 1/2" apron inset in cabinet.

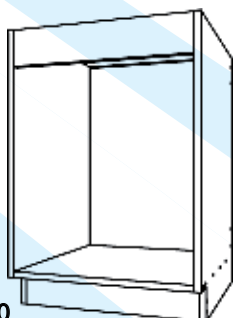

**AVC110**

Open Sink Cabinet

- 7 1/2" Apron
- Interior surface shall be as listed on order form unless noted differently

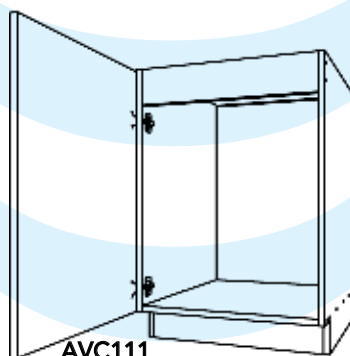

**AVC111**

One Door Sink Cabinet

- 7 1/2" Apron behind door

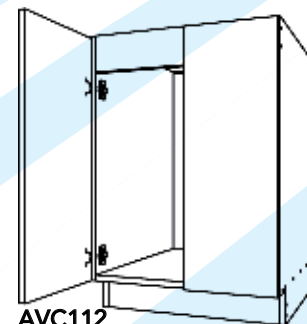

**AVC112**

Two Door Sink Cabinet

- 7 1/2" Apron behind door

# 2 Series - Base with Drawers

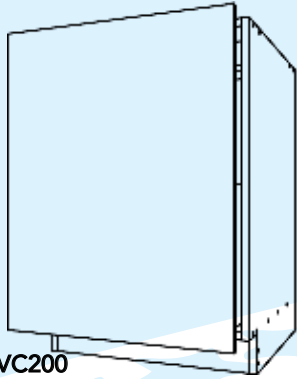

**AVC200**  
One-Drawer Base Cabinet

- Full height drawer

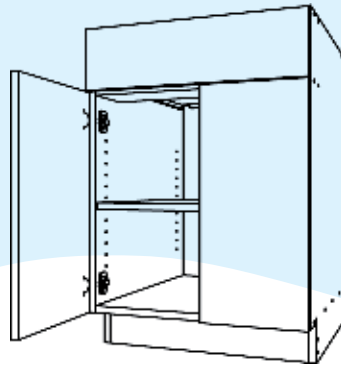

**AVC201**  
Two-Door Base Cabinet

- One Wide Drawer
- Specify type and number of shelves on order form

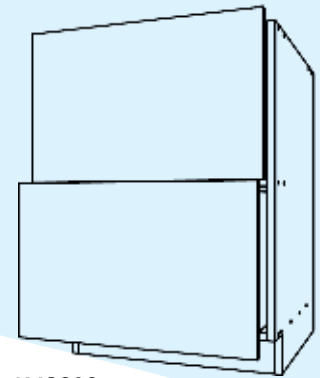

**AVC202**  
Two-Drawer Base Cabinet

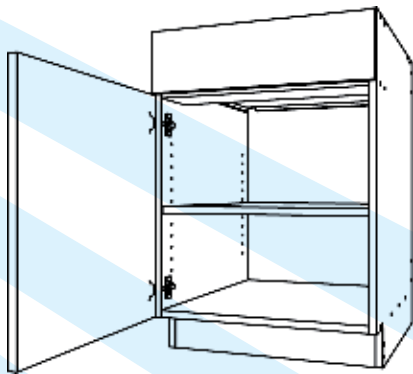

**AVC203**  
One-Drawer Open Base Cabinet

- Specify opening height
- Interior surface shall be as listed on order form unless noted differently

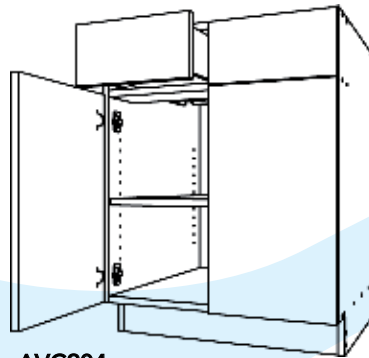

**AVC204**  
Two-Door Base Cabinet - Two-Drawer

- Specify type and number of shelves per opening on order form

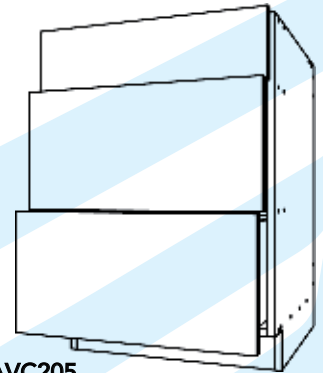

**AVC205**  
Three-Drawer Base Cabinet

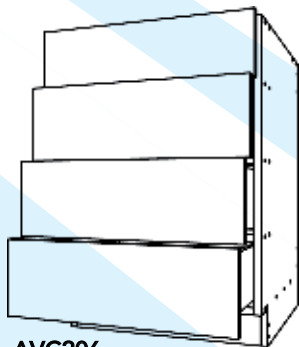

**AVC206**  
Four-Drawer Base Cabinet

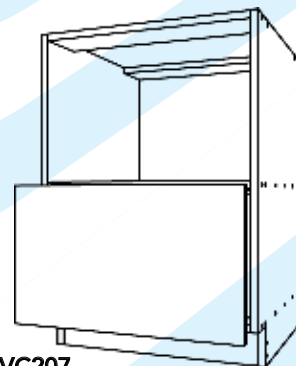

**AVC207**  
One-Drawer Open Base Cabinet

- Specify opening height
- Interior surface shall be as listed on order form unless noted differently

# 3 Series - Upper Cabinets

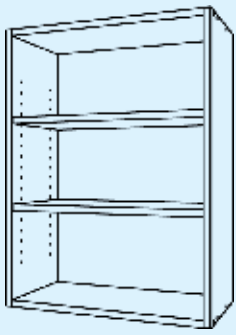

**AVC300**

Open Upper Cabinet

- Specify type and number of shelves on order form
- Interior surface shall be as listed on order form unless noted differently

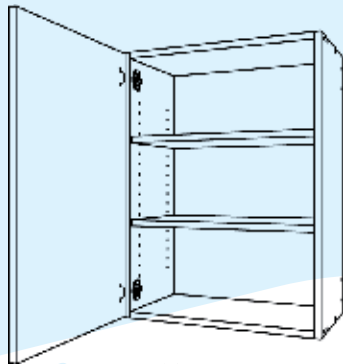

**AVC301**

One-Door Upper Cabinet

- Specify type and number of shelves on order form

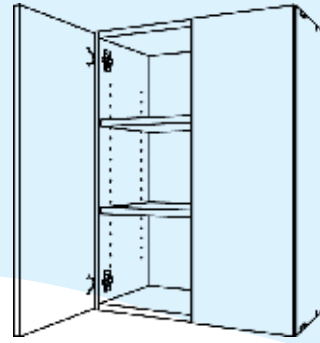

**AVC302**

Two-Door Upper Cabinet

- Specify type and number of shelves on order form
- Interior surface shall be as listed on order form unless noted differently

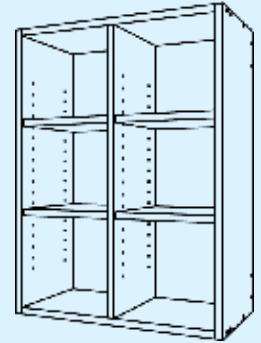

**AVC303**

Open Upper Cabinet

- One vertical divider
- Specify type and number of shelves per opening on order form
- Interior surface shall be listed on order form unless noted differently

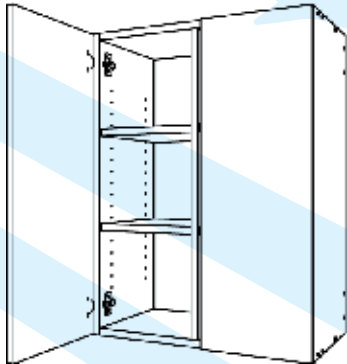

**AVC304**

Two-Door Upper Cabinet

- One vertical divider
- Specify type and number of shelves per opening on order form

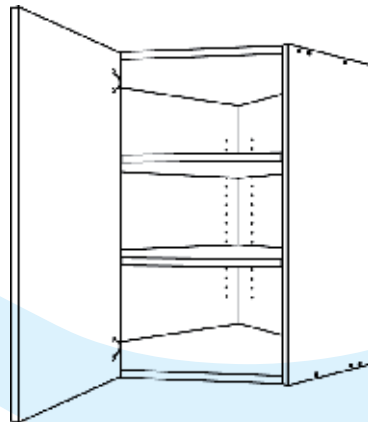

**AVC306** (Angle Corner 2)

One-Door at 45° Angle Corner Upper Cabinet

- Specify type and number of shelves per opening on order form

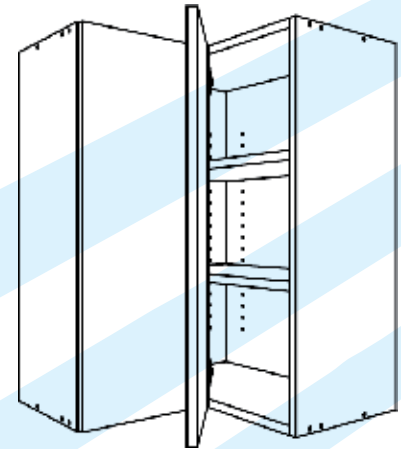

**AVC305** (L-Shaped 2)

Two-Door Upper Corner Cabinet

- Doors are hinged left or right and bi-fold in the center
- Specify type and number of shelves on order form

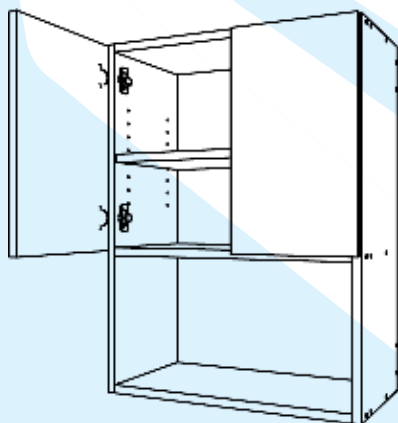

**AVC307**

Partial Open Upper Cabinet - Two Doors

- Specify inside clear height of bottom opening

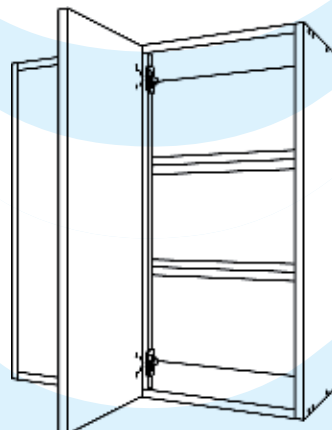

**AVC308** (Blind Corner 1)

One-Door Corner Upper Cabinet with False Panel

- Specify type and number of shelves per opening on order form
- Specify width of false panel
- Specify hinge right or left for false panel on opposite side

# 4 Series - Tall Cabinets

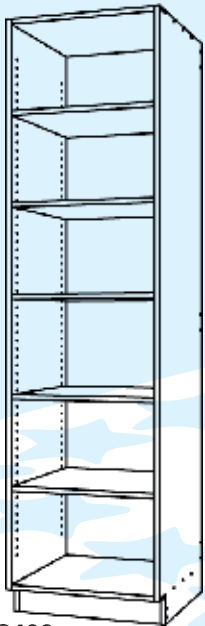

**AVC400**  
Open Tall Cabinet

- Specify type and number of shelves on order form

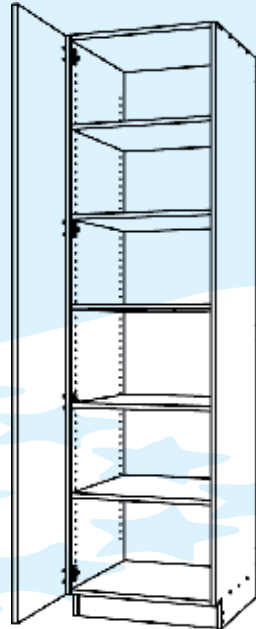

**AVC401**  
Open-Door Tall Cabinet

- Specify type

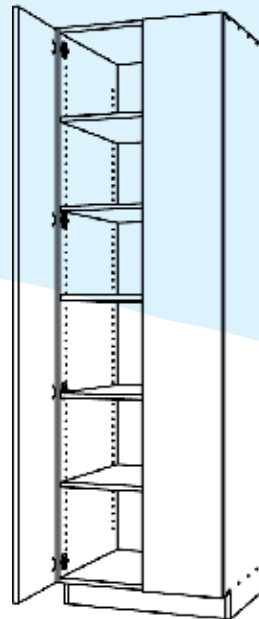

**AVC402**  
Two-Door Tall Cabinet

- Specify type

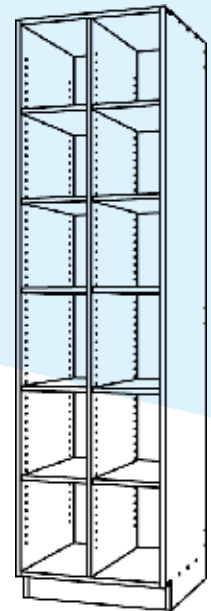

**AVC403**  
Open Tall Cabinet

- Open vertical divider
- Specify type and number of

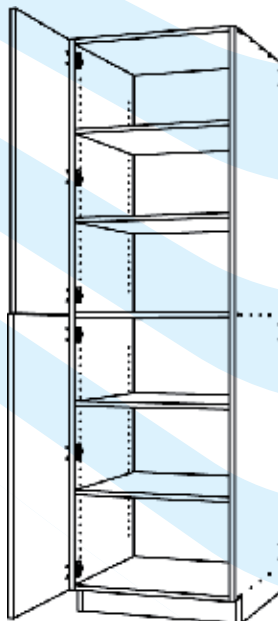

**AVC404**  
Two-Door Tall Cabinet

- Specify type and number of shelves on order form
- Specify inside clear opening height on top section

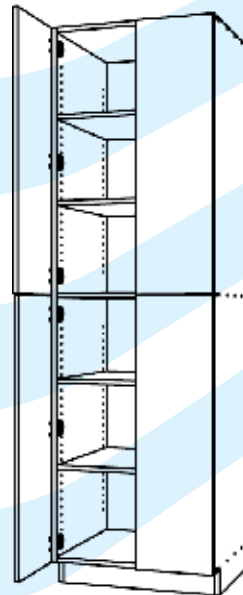

**AVC405**  
Tall Cabinet - Four Doors - Split Height

- Specify door heights
- Specify type and number of shelves on order form

# 5 Series - Tall Cabinets with Drawers

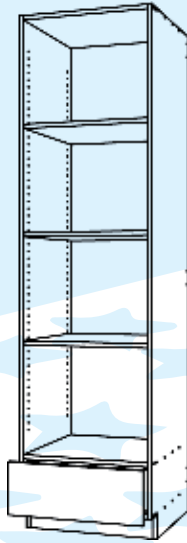

## AVC500

Open Tall Cabinet - One Drawer

- One Fixed shelf standard
- Specify drawer front height
- Specify number of adjustable shelves
- Interior surface shall be as listed on order form unless noted differently

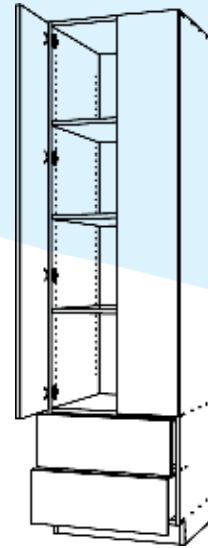

## AVC501

Two-Door Tall Cabinet - Two Drawers

- 1 Fixed shelf standard
- Specify drawer front heights
- Specify number of adjustable shelves

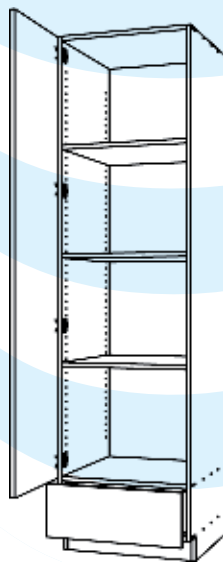

## AVC502

One-Door Tall Cabinet - One Drawer

- One fixed shelf standard
- Specify drawer front height
- Specify number of adjustable shelves

# 6 Series - Tall Cabinets for Oven

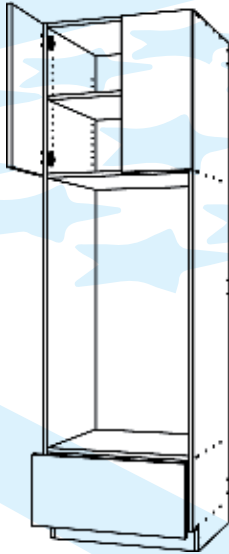

## **AVC600**

Tall Cabinet for Oven -  
Two Doors

- Specify height for drawer front
- Specify inside clear opening height
- Specify type and number of shelves on order form

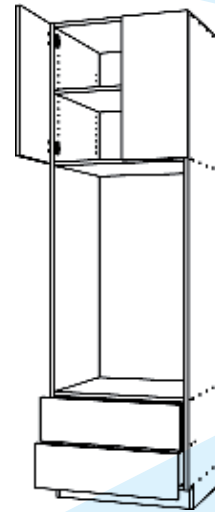

## **AVC601**

Two-Door Open Tall Cabinet -  
Two Drawers

- Two fixed shelf standard
- Specify drawer box and opening heights
- Specify number of adjustable shelves
- Interior surface shall be as listed on order form unless noted differently



# FREE QUOTE REQUEST



Project Name or Number \_\_\_\_\_

Contact Name \_\_\_\_\_

Cell \_\_\_\_\_

Company Name \_\_\_\_\_

Phone \_\_\_\_\_

Fax \_\_\_\_\_

Street Address \_\_\_\_\_

Email \_\_\_\_\_

City, State, ZIP Code \_\_\_\_\_

How did you know about us? \_\_\_\_\_

- 1 Project Type**  Flat-stacked parts  
 Assembled cabinets

- 2 Cabinet Materials**
- Particleboard**  
 Melamine Color \_\_\_\_\_
- Plywood**  
 Veneer Type \_\_\_\_\_  
 Stain Grade  Paint Grade  
 Pre-Finished
- MDF**  
 Raw  Veneer type \_\_\_\_\_  
 Other \_\_\_\_\_

- 3 Finished Ends**  
 Color \_\_\_\_\_
- Exposed Interiors**  
 Color \_\_\_\_\_
- Wall Bottom Material**  
 Match Interior  Match Exterior

- 4 Edge Banding**
- Cabinet: Color \_\_\_\_\_  
 PVC  Veneer  P- LAM  
 Thickness:  1/2mm  1 mm
- Adjustable shelf Color \_\_\_\_\_  
 PVC  Veneer  P- LAM  
 Thickness:  1/2mm  1 mm
- Doors and drawers: Color \_\_\_\_\_  
 PVC  Veneer  P- LAM  
 Thickness:  1/2mm  1 mm  3mm

- 5 Doors & Drawers**
- Provide doors & Drawers Fronts**  Yes  No  
 **SLAB Doors & Drawer Fronts**  
 Material type & color No: \_\_\_\_\_  
 Grain Matching:  Yes  No  
 Core  Melamine  Plywood  MDF  P.B.  
 **Wood Doors & Drawers**  
 3<sup>rd</sup> company supplier \_\_\_\_\_ Wood type \_\_\_\_\_  
 Wood doors style \_\_\_\_\_ Edge detail \_\_\_\_\_
- Drawer Guides**  
 Provide Drawer Guides with order  Yes  No  
 Side Mount  Undermount  
 Drawer Guides brand \_\_\_\_\_
- Drawer Box Parts**  
 Provide Drawer Boxes with order  
 Yes  No  
 Melamine: Color \_\_\_\_\_

- 6 Cabinet Line (Bore) Drill**
- A) Full 32 mm Line Bore  
 B) Bore only required holes
- How may holes per shelf:  
 1 hole  3 holes  
 5 holes  7 holes

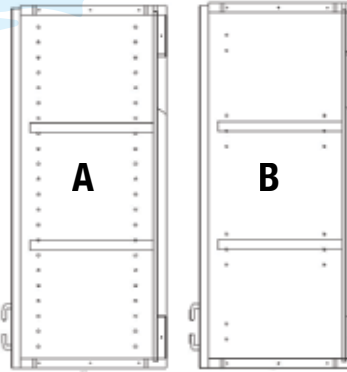

- 7 Base cabinet tops**  
 A) Top stretchers  B) Full tops

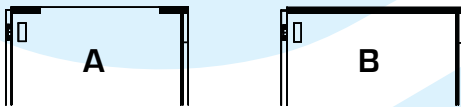

- Drawer Stretchers**  
 A) Top Drawer Only  
 B) At All Drawers  
 C) No Stretchers

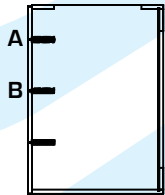

- Prefinished Maple Ply  
 **1/2 Dovetail Drawers**  
 Baltic Birch  Solid Wood Maple
- Hinges**  
 Provide Hinges with Order  Yes  No  
 Wing mounting plate  Yes  No  
 In line mounting plate  Yes  No
- 120° Blum Standard Hinges  
 110° Blum Soft Close Hinges

- 8 Fillers**  
 Yes  No  
 Materials width \_\_\_\_\_ Qty \_\_\_\_\_

- 9 Cabinet Ends Type**  
 Base cabinet ends to floor  
 Tall cabinet ends to floor

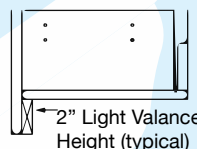

- Doors and Drawer Reveal**  
**Base Cabinet Top** \_\_\_ **Bottom** \_\_\_  
**Wall and tall Cabinet Top** \_\_\_ **Bottom** \_\_\_  
**Side Reveal** \_\_\_
- Toe Kick Parts**  
 Do Not Supply  
 Provide Leg Levelers
- Provide Ripped Material Same as Door**  
 Height  
 Build Toe Kick:  Yes  No  
 Plywood  
 Melamine  
 Height

- 10 Hanging Cleats**  
 Route un Finished Ends for Hanging Cleats  
 Supply Hanging Cleats
- Light Valance**  
  
 ← 2" Light Valance Height (typical)

- Ripped Material 96"  
 Valance Height  2"  Other \_\_\_"Qty \_\_\_\_\_



- 11 Finished Ends**
-   
 Doweled  Cabineo  Applied
-   
 Base Finished End Scribe \_\_\_\_\_  
 Wall Finished End Scribe \_\_\_\_\_



## WHAT WE OFFER

Our staff understands customers' expectations, and therefore provides material/components parts that meet their needs. We handle small-scale and large-scale projects with ease. Our well-knowledged team in conjunction with our business partners are here to assist you with all your constructions needs in the following industries:

- Health Furniture and Interiors
- School Furniture and Interiors
- Kitchen Cabinetry
- Office Furniture
- Home Office Furniture
- Retail Store Fixtures and Displays
- Hotel Furniture
- Household Laminated Furniture
- Restaurant Tables, Booths and Interiors
- Residential Closet and Garage Organizers

 (805) 298-4411  
 [info@americanvisioncabinets.com](mailto:info@americanvisioncabinets.com)  
 [www.AmericanVisionCabinets.com](http://www.AmericanVisionCabinets.com)  
 270 N Aviator Street, #D, Camarillo, CA 93010



AMERICAN VISION  
CABINETS INC.